

Overview RFC – Fuel Nipple

RFC-88-N

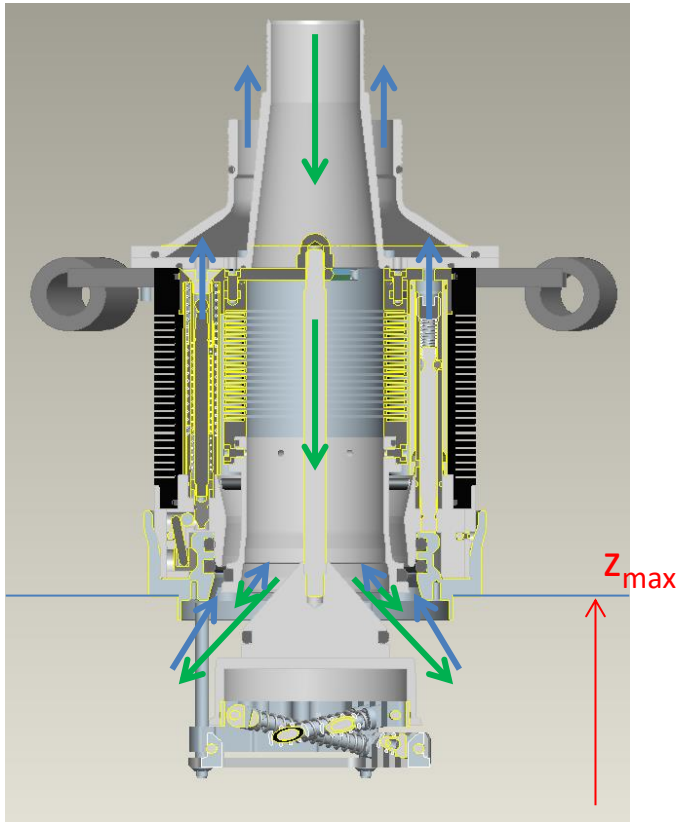

- Fuel- /Airflow not separated
- Nipple has to be mounted on top of the fuel tank
- For defueling
- ➔ Slower refueling process

RFC-88-TN

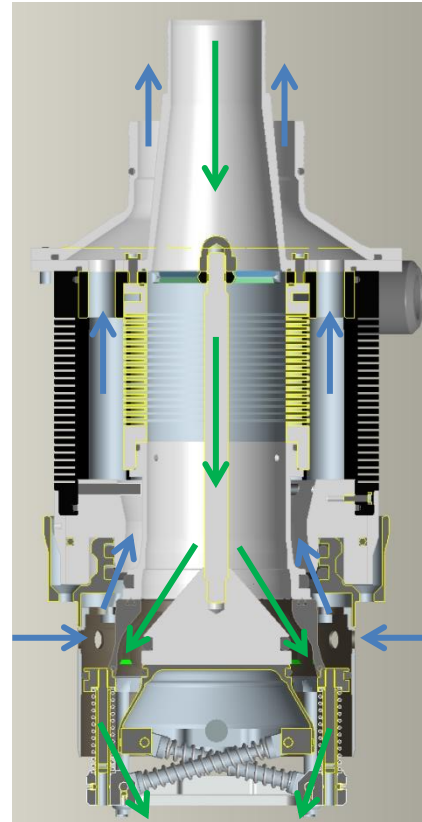

- Fuel- /Airflow separated
- Bleeding separated (s. RFC-88-TN-Col)
- ➔ Faster refueling process

RFC-88-DN

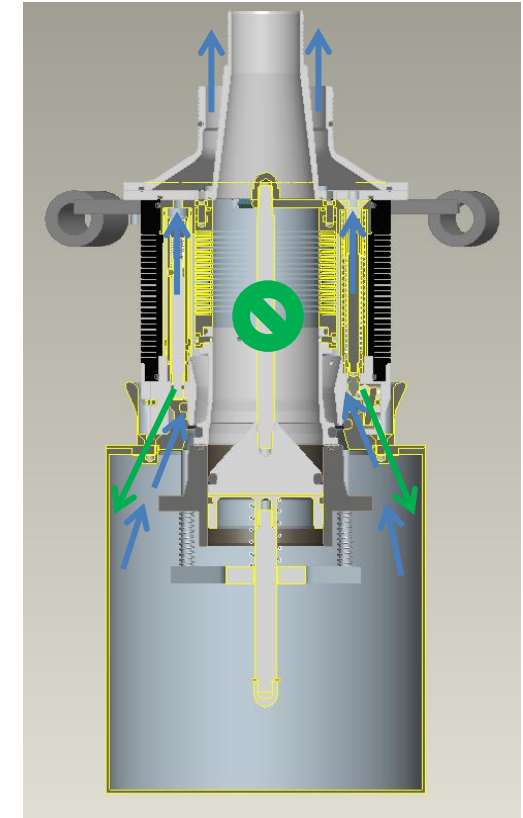

- Drain-Nipple to drain vent hose